



ROYAL YACHT CLUB OF VICTORIA

Off-the-Beach Season

2018 - 2019 Season

Sailing Instructions

Organising Authority: - Royal Yacht Club of Victoria

1. Rules

The Regatta will be governed by:

- The Racing Rules of Sailing, 2017-2020 (RRS)
- The rules of the ICCA and other class associations
- Amendments defined in the notice of race
- Amendments defined by these sailing instructions.

Australian Sailing Special Regulations Part 2 Off the Beach Boats will apply. It will be the responsibility of all competitors to ensure that personal flotation devices comply with a standard equivalent to those listed in RRS AS SR Part 2 R1 Personal Buoyancy

2. Notices to Competitors

- 2.1 Notices to competitors will be posted on the official notice board located in the OTB Club room.

3. Changes to Sailing Instructions

- 3.1 Any change to the Sailing Instructions will be posted before 1000 hours on the day it will take effect, except that any changes to the schedule of races will be posted by 1500 hours, 5 days before it will take effect.

4. Signals Made Ashore

- 4.1 Signals will be displayed from the OTB mast adjacent to the Cadet Boatshed.
- 4.2 When Code flag "AP" is displayed ashore, '1 minute' is replaced with 'not less than 30 minutes' in race signal AP.
This alters RRS Race Signals

5. Schedule of Races

- 5.1 The schedule is as per RYCV OTB Calendar 2018/2019 as displayed on the RYCV OTB web page and OTB Race Notice board in the OTB Club room.

6. Class Flag

- 6.1 For International Cadet Class, the class flag will be code flag 'Y'. For the 29er Class it will be the 29er Class flag. For other classes, the class flag will be code flag 'W' unless otherwise advised in the pre-race briefing

7. The Courses

- 7.1 The diagrams in Attachment A show the courses, the order in which the marks are to be passed and the side on which each mark is to be left.
- 7.2 In the event that a gate mark is missing, a single mark at the gate location shall be rounded to port
- 7.3 No later than the warning signal, the race committee boat will display the course to be sailed

8. Marks

- 8.1 Marks
 - Start / Finish mark will be an Orange cylindrical buoy
 - For courses with a separate finish line, the Finish mark will be a Blue cylindrical buoy. For courses with a common start/finish line, the Finish mark will be an Orange cylindrical buoy
 - All marks of the course will be Yellow cylindrical buoys
- 8.2 Change of course
 - New marks will be a Yellow cylindrical buoy with black band

9. The Start

- 9.1 Races will be started by using rule 26 with the warning signal made five minutes before the starting signal.
- 9.2 The starting line shall be between the Start mark and the flagstaff displaying an Orange flag on the Race Signal Vessel.

- 9.3 A boat starting later than 5 minutes after her starting signal will be scored DNS. This changes RRS A4.

10. Alteration or shortening course

- 10.1 The Race Committee may change the course in accordance with RRS 33.
- 10.2 The Race Committee may finish a race at any mark of the course in accordance with RRS 32.1 and the RRS race signal 'S'.

11. The Finish

- 11.1 The finishing line shall be between the finish mark and a flagstaff displaying an Orange flag. A blue flag may be flown to indicate the vessel is on station for finishing.

12. Time Limit

- 12.1 The Time Limit for all races shall be 2 hours. Boats not finished 20 minutes after the first boat to finish may be scored as they are positioned on the course. This changes RRS 35, A4 and A5

13. Penalty System

- 13.1 Appendix P may apply as changed herein. Rule P2.3 will not apply and rule P2.2 is changed so that it will apply to any penalty after the first one
- 13.2 A boat that has taken a penalty or retired in accordance with rule 31.2 or 44.1 shall complete an acknowledgment form at the Race Office before the end of the protest time limit.
- 13.3 Appendix P (special procedures for rule 42) will apply as changed by instructions 14.2 and 14.4
- 13.4 Boats failing to sign on or sign off shall be penalised 2 points without a hearing. This changes 63.1.

14. Protests

- 14.1 Submission of Protests:
Boats intending to protest shall inform the committee vessel at the end of the race and before returning to shore. Upon returning to shore, protests shall be made in writing and delivered to the RO at the OTB Club room within the protest time limit. Protest forms are available at the OTB club room or at the main Club office
- 14.2 Protest time limit:
The protest time limit is 60 minutes after the last boat has finished the last race of the day. The same time limit applies to protests by the race committee and the protest committee about incidents they observe in the racing area and to requests for redress. This changes rules 61.3 and 62.2.

14.3 Hearing of protests:

Notices will be posted within 60 minutes after the expiration of the protest time limit to inform competitors where and when there is a hearing in which they are parties to a protest or named as a witness. This shall be taken as notification to all parties. Notices of protests by the race committee or protest committee will be posted to inform boats under rule 61.1(b).

14.4 A list of boats that, under SI 14.2, have acknowledged breaking rule 42 or have been disqualified by the protest committee will be posted within the protest time limit.

14.4 Breaches of NOR, Sis, 14.2, 16, 17, 18 and 20 shall not be grounds for a protest by a boat. This amends rule 60.1(a). Penalties for these breaches may be less than disqualification, if the Protest committee so decides. This amends rule 64.1(a).

15. Scoring

15.1 As per the Notice of Race

16. Safety Regulations

16.1 Buoyancy Aids:

All competitors shall wear while racing, personal flotation devices that are in good condition and are in accordance with the specifications issued by or approved by a national authority affiliated to the ISAF, or standards organisation, or certification authority recognised for the purpose by government. Government regulations require that competitors shall wear personal flotation devices at all times while afloat. This changes rule 40.

16.2 Sign On/Off.

An Official Sign on/off sheet is provided in the OTB club room prior and after the race. The boat, skipper and crew's name and sail number shall be written clearly on the Sign On Sheet. On returning to shore it is the Skipper's responsibility to ensure the sign on sheet is promptly signed off to signify that you have returned. Failing to comply may result in the boat offending being scored DNC.

16.3 Shipping

All yachts should be aware of shipping operating in the Port of Melbourne. They shall obey all Port regulations. All care should be taken while crossing Shipping channels. Any boat leaving the course area shall advise an official boat as soon as practical. Crossings should be made whenever possible under the supervision of a safety or support boat. Yarra River Channel Mark 17A (located Adjacent the Navy Pier) is the assembly point for competitors to obtain permission from an official club boat to cross the channel. Any action that brings a vessel to the notice of the race committee or the harbour authority during that vessels channel crossing, may be disqualified for that days racing.

16.4 Official vessels

Boats, when not racing, are particularly requested to give race official boats right of way and ample room to manoeuvre when they are engaged in official race duties.

17. Replacement of Crew or equipment

17.1 Substitution of Skippers will not be allowed and substitution of Crew or equipment will only be permitted if made in writing to the Race Committee at least 1 hour before the scheduled time of the first race affected. Such permission is not valid unless it is given in writing. Any substituted junior crew must have a valid Parent consent form submitted to the Organising Authority.

18. Equipment and Measurement checks

18.1 At the direction of the RO, a boat or equipment may be inspected at any time for compliance with the class rules and sailing instructions.

19. Official Boats

19.1 Official Boats such as Judge, Coach or Media boats will be identified at the briefing.

19.2 Race committee boats and patrol boats may display the RYCV Burgee.

20. Support Boats

20.1 Although coaching by the Official Club Coach Staff may be allowed during the race, Coach and Support boats are requested not to hinder any competitor during racing or favour any boat, during an event.

20.2 When requested by the Race Officer, all support boats shall provide assistance to boats in distress in the accepted manner.

21. Radio Communication.

21.1 A boat shall neither make radio transmissions while racing nor receive radio communications not available to all boats. This also applies to mobile telephones.

22. Prizes.

22.1 Will be awarded as per the Notice of Race Addendum A.

22.2 Only financial members of the Royal Yacht Club of Victoria are eligible for prizes.

22.3 A special trophy may be awarded to the best placed visitor.

23. Disclaimer of Liability.

- 23.1 Competitors participate in the Regatta entirely at their own risk. See RRS rule 4, Decision to Race. The organising authority will not accept any liability for material damage, personal injury or death sustained in conjunction with or prior to, during, or after the regatta. Refer to the declaration on the official sign on form.

24. Indemnity and Safety Form.

- 24.1 An Indemnity and Safety Declaration Form must be signed by all competing junior sailors and their parent or guardian. These forms are available on the RYCV website and forms will also be available at the Cadet Canteen- Room. Once submitted it is valid for the season.

25. Insurance.

- 25.1 All competing boats shall carry, as a minimum, Third Party Liability insurance, with racing risk, to the minimum value of \$10,000,000.

Attachment A

Course Illustrations – Windward Leeward

L

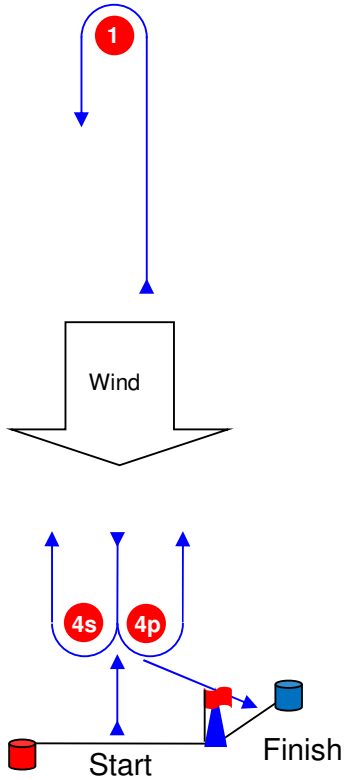

Course: Leeward finish

Signal	Mark Rounding Order
L2	Start – 1 – 4s/4p – 1 – 4p – Finish
L3	Start – 1 – 4s/4p – 1 – 4s/4p – 1 – 4p – Finish
L4	Start – 1 – 4s/4p – 1 – 4s/4p – 1 – 4s/4p – 1 – 4p – Finish

W

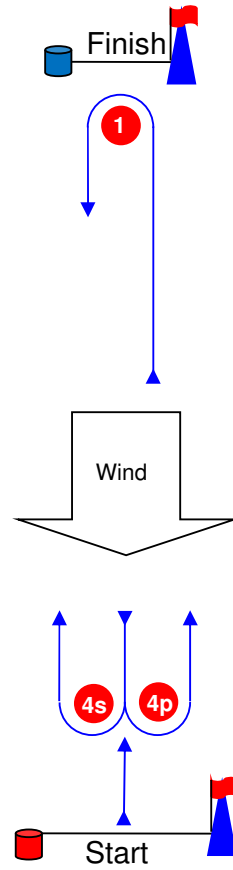

Course: Windward Finish

Signal	Mark Rounding Order
W2	Start – 1 – 4s/4p – Finish
W3	Start – 1 – 4s/4p – 1 – 4s/4p – Finish
W4	Start – 1 – 4s/4p – 1 – 4s/4p – 1 – 4s/4p – Finish

LA / WA

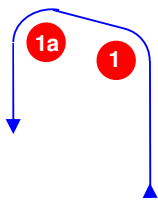

Course: Windward/leeward with offset mark 1a

Signal	Mark Rounding Order
LA2	Start – 1 – 1a – 4s/4p – 1 – 1a – 4p – Finish
LA3	Start – 1 – 1a – 4s/4p – 1 – 1a – 4s/4p – 1 – 1a – 4p – Finish
LA4	Start – 1 – 1a – 4s/4p – 1 – 1a – 4s/4p – 1 – 1a – 4s/4p – 1 – 1a – 4p – Finish
WA2	Start – 1 – 1a – 4s/4p – Finish
WA3	Start – 1 – 1a – 4s/4p – 1 – 1a – 4s/4p – Finish
WA4	Start – 1 – 1a – 4s/4p – 1 – 1a – 4s/4p – 1 – 1a – 4s/4p – Finish

Course Illustrations – Triangular course

T

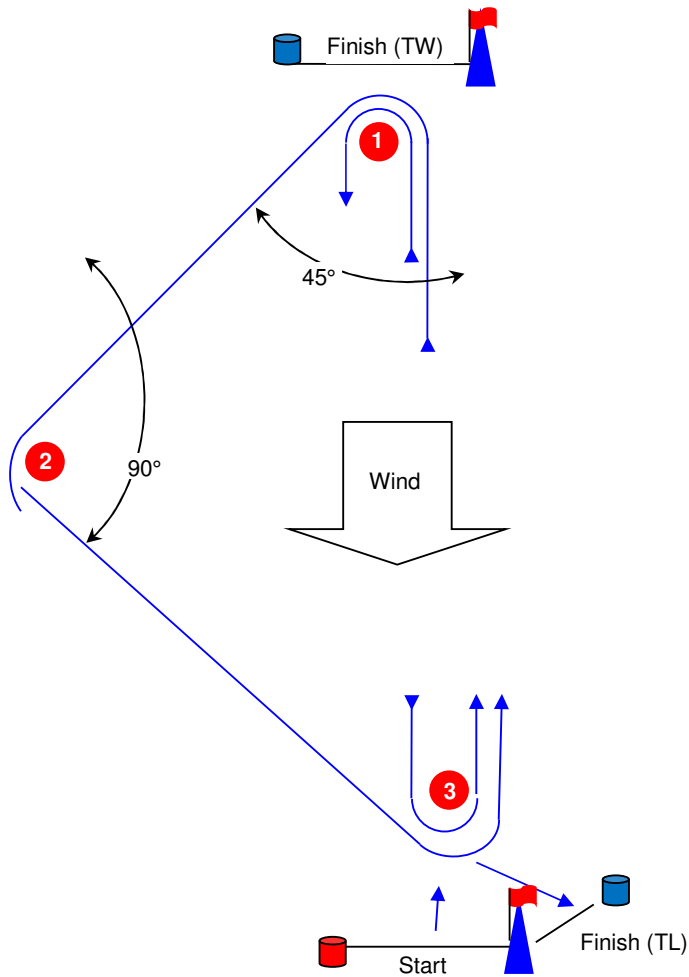

Course: Triangular

Signal	Mark Rounding Order	Signal	Mark Rounding Order
TW2	Start – 1 – 2 – 3 – Finish	TL2	Start – 1 – 2 – 3 – 1 – 3 - Finish
TW3	Start – 1 – 2 – 3 – 1 – 3 – Finish	TL3	Start – 1 – 2 – 3 – 1 – 3 – 1 – 3 - Finish
TW4	Start – 1 – 2 – 3 – 1 – 3 – 1 – 2 – 3 – Finish	TL4	Start – 1 – 2 – 3 – 1 – 3 – 1 – 2 – 3 – 1 – 3 - Finish

Course Illustrations – Trapezoid with beat to finish. Start and finish by signal boat

I

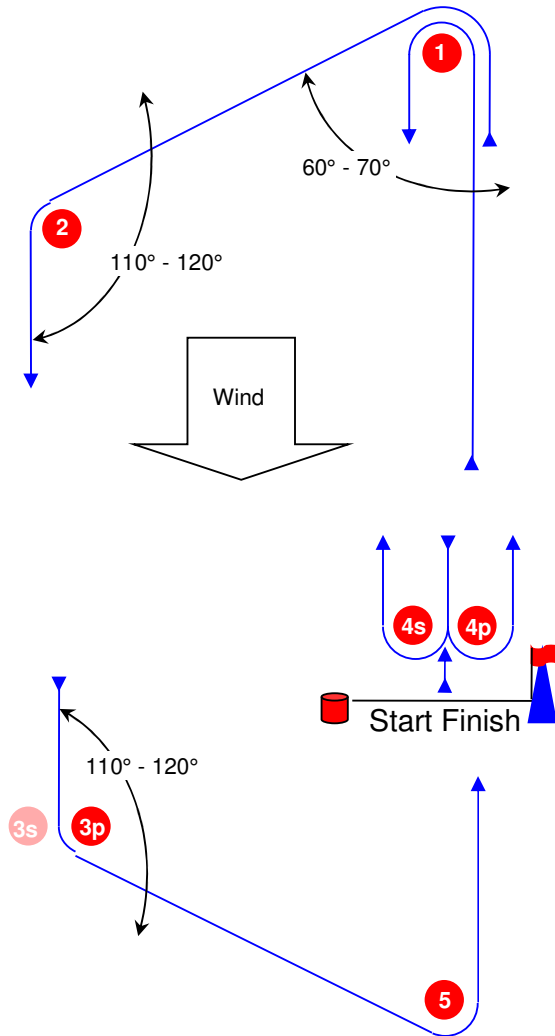

Course: Inner Trapezoid with beat to finish

Signal	Mark Rounding Order
I2	Start - 1 - 4s/4p - 1 - 2 - 3p - 5 - Finish
I3	Start - 1 - 4s/4p - 1 - 4s/4p - 1 - 2 - 3p - 5 - Finish
I4	Start - 1 - 4s/4p - 1 - 4s/4p - 1 - 4s/4p - 1 - 2 - 3p - 5 - Finish

O

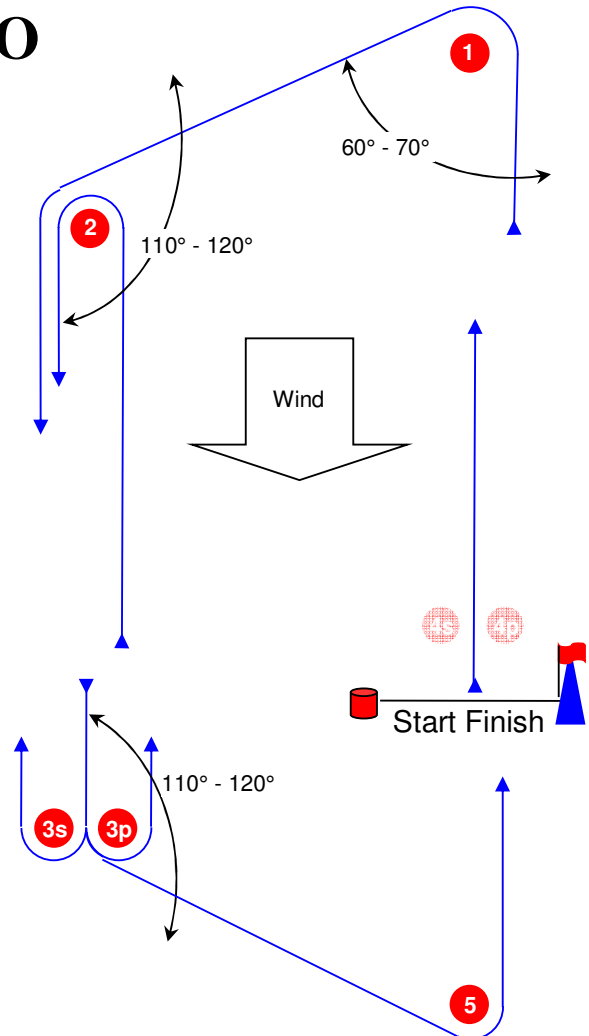

Course: Outer Trapezoid with beat to finish

Signal	Mark Rounding Order
O2	Start - 1 - 2 - 3s/3p - 2 - 3p - 5 - Finish
O3	Start - 1 - 2 - 3s/3p - 2 - 3s/3p - 2 - 3p - 5 - Finish
O4	Start - 1 - 2 - 3s/3p - 2 - 3s/3p - 2 - 3s/3p - 2 - 3p - 5 - Finish

List of amendments

6th August 2018 Initial issue for season 2018/2019